

STAINLESS STEEL SOLENOID VALVES

Dependable • Packless



TYPE "WR" FULL PORT - NORMALLY OPEN 1/2" TO 3" PIPE SIZE

NO DIFFERENTIAL PRESSURE REQUIRED TO OPEN

MAX. FLUID TEMP.
400° F
MAX. STATIC PRESSURE
200 PSI

OPERATION:

Valve closes when energized and opens when de-energized. When the coil is energized the plunger presses the poppet, closing the pilot orifice, and opens a bleed passageway to permit pressure to build above the piston and seat it. Upon de-energizing the coil, the pilot orifice is opened, relieving the pressure above the piston allowing it to leave its seat. The bottom spring allows the valve to operate at zero pressure drop.

CONSTRUCTION:

- (*Wetted parts - No Copper Bearing Alloys in contact with fluid)
- *Valve Body - 304 Stainless Steel Globe Pattern - NPT ends
(For Flanged Ends see Options page 24)
- *Piston - 303 Stainless Steel
Coil Enclosure - Malleable or Cast Iron, 1/2" NPS conduit conn.
- *Plunger - 430 Stainless Steel
- *Poppet - 303 Stainless Steel
- *Stem - 303 Stainless Steel
- *Bonnet Tube - 304 Stainless Steel
- *Spring - Inconel
- *Body Seal - Non Asbestos Gasket
- *Orifice Seal - Glass Filled Teflon
- *AC Shading Coil - Silver
- *Stem Pin - 304 Stainless Steel
Coil - Encapsulated Class H, 18" leads

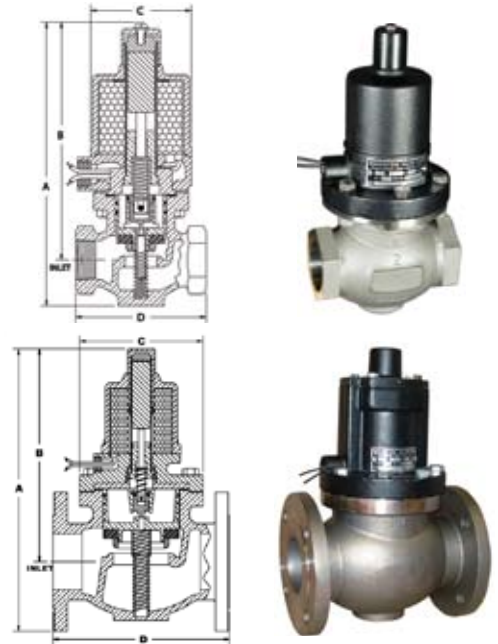

**FOR OPTIONS & ACCESSORIES
SEE PAGES 24 & 25**

APPLICATION:

To control the flow of STEAM. Steam must be free of sediment. Valve operates from zero to maximum differential pressure indicated in table. Valve must be mounted in horizontal pipe with solenoid enclosure vertical and on top.

Strainers are recommended for use with solenoid valves (See page 19)

When you order please supply the following:

- Pipe Size
- Valve Type
- Voltage (AC or DC)
- Hertz
- Fluid
- Fluid Temperature
- Max. Diff. Pressure
- Optional Features

(See pages 24 & 25)

Pipe Size Inches	Max. Diff. PSI	Type No.	Watts AC	Amps Hold 120-60	Amps Inrush 120-60	Watts DC	Ship Wt. Lbs.	Dimensions In Inches					
								A	B	C	D	D (Flanged) 150#	
1/2	90	14WR22	25	0.5	1.5	18	7	8-1/8	7	2-7/8	3-1/4	6	
	140	114WR42	40	0.8	2.4	28		9-1/8	8	3-1/2			
	180	129WR42	65	1.5	4.2	33		10	9-1/8	8			3-1/2
3/4	50	14WR23	25	0.5	1.6	18	8	8-1/4	7-1/8	2-7/8	3-1/2	6	
	110	114WR43	40	0.8	2.6	28		9-1/4	8-1/8	3-1/2			
	180	129WR43	65	1.5	4.3	33		12	9-1/4	8-1/8			3-1/2
1	25	16WR14	25	0.5	1.8	18	10	9-1/8	7-3/4	3-1/4	4-1/8	6-1/2	
	50	116WR24	40	0.8	2.9	28		10	9-1/8	7-3/4			3-1/4
	90	116WR44	40	0.8	2.9	28		10	9-1/8	7-3/4			3-1/4
	180	131WR44	65	1.5	4.5	33		14	10	8-5/8			3-1/2
1-1/2	25	35WR16	45	1.0	3.8	23	18	11-3/8	9-1/2	4	4-7/8	6-1/2	
	50	35WR26	45	1.0	3.8	23		11-3/8	9-1/2	4			
	90	135WR46	65	1.5	5.7	33		22	11-5/8	9-3/4			4-1/2
	180	141WR46	85	3.5	9.7	45		22	11-5/8	9-3/4			4-1/2
2	25	36WR17	45	1.0	4.2	23	27	12-3/8	10-1/8	5-3/8	6	8	
	50	36WR27	45	1.0	4.2	23		12-3/8	10-1/8				
	115	42WR47	60	1.7	7.3	35		32	12-5/8				10-3/8
3	25	44WR19F1	60	1.7	8.8	35	69	14-3/8	11-1/8	6-5/8	N/A	9-1/2	
	50	44WR29F1											
	100	44WR49F1											
	150	144WR49F1											

Shipping Weights above apply to Threaded Ends Only (except 3" which are Flanged Only)
For Flanged Ends contact factory for complete weight and dimensions
3" STAINLESS STEEL VALVES ARE SUPPLIED WITH FLANGED ENDS ONLY

MAGNATROL VALVE CORPORATION