

STAINLESS STEEL SOLENOID VALVES

Dependable • Packless



TYPE "KR" FULL PORT - NORMALLY OPEN 1/2" TO 3" PIPE SIZE

NO DIFFERENTIAL PRESSURE REQUIRED TO OPEN

OPERATION:

Valve closes when energized and opens when de-energized. When the coil is energized the plunger presses the poppet, closing the pilot orifice, and opens a bleed passageway to permit pressure to build above the piston and seat it. Upon de-energizing the coil, the pilot orifice is opened, relieving the pressure above the piston allowing it to leave its seat. The bottom spring allows the valve to operate at zero pressure drop.

CONSTRUCTION:

(*Wetted parts - No Copper Bearing Alloys in contact with fluid)

*Valve Body - 304 Stainless Steel Globe Pattern - NPT ends

(For Flanged Ends see Options page 24)

*Piston - 303 Stainless Steel

Coil Enclosure - Malleable or Cast Iron, 1/2" NPS conduit conn.

*Plunger - 430 Stainless Steel

*Poppet - 303 Stainless Steel

*Stem - 303 Stainless Steel

*Bonnet Tube - 304 Stainless Steel

*Spring - Inconel

*Body Seal - Non Asbestos Gasket

*Orifice Seal - Glass Filled Teflon

*AC Shading Coil - Silver

*Stem Pin - 304 Stainless Steel

Coil - Encapsulated Class H, 18" leads

**FOR
STEAM APPLICATIONS
SEE BULLETIN 3006-WR
Page 23**

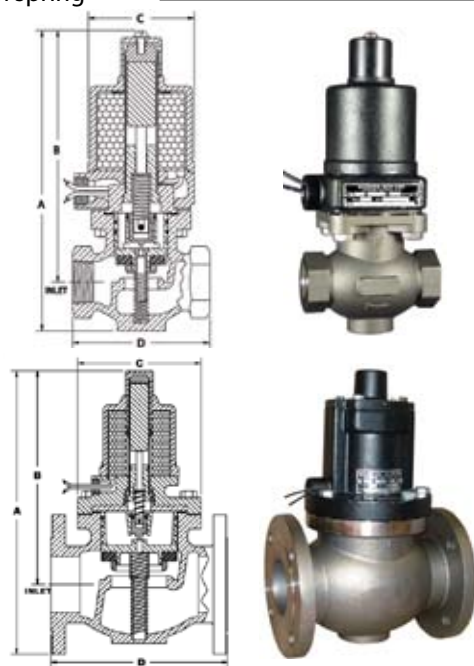

**MAX. FLUID TEMP.
400° F**

**MAX. STATIC PRESSURE
300 PSI**

Except valves listed for 500 PSI

APPLICATION:

To control the flow of Corrosive Fluids, Deionized Water, Condensate, Ammonias, Vegetable Oils, Fuel Oils, Cryogenics, Flammable Liquids.** Cryogenic fluids include liquid oxygen (-297°F), liquid argon (-303°F) and liquid nitrogen (-320°F). Valve operates from zero to maximum differential pressure indicated in table. Valve must be mounted in horizontal pipe with solenoid enclosure vertical and on top.

** CLEANING

- Cryogenic valves are degreased & cleaned to keep them free of moisture.
- Oxygen valves are also "black light" tested.

Strainers are recommended for use with solenoid valves
(See page 19)

When you order please supply the following:

- Pipe Size
 - Valve Type
 - Voltage (AC or DC)
 - Hertz
 - Fluid
 - Fluid Temperature
 - Max. Diff. Pressure
 - Optional Features
- (See pages 24 & 25)

FOR OPTIONS & ACCESSORIES SEE PAGES 24 & 25

Pipe Size Inches	Max. Diff. PSI	Type No.	Watts AC	Amps Hold 120-60	Amps Inrush 120-60	Watts DC	Ship Wt. Lbs.	Dimensions In Inches					
								A	B	C	D	D (Flanged)	
												150#	300#
1/2	110	14KR42	25	0.5	1.5	18	7	8-1/8	7	2-7/8	3-1/4	6	6-1/2
	200	14KR32						9-1/8					
	300	29KR52	10	4									
	500	E29KR62											
3/4	110	14KR43	25	0.5	1.6	18	8	8-1/4	7-1/8	2-7/8	3-1/2	6	6-1/2
	200	29KR33						9-1/4					
	300	129KR53	12	4									
	500	E129KR63											
1	110	16KR44	25	0.5	1.8	18	10	9-1/8	7-3/4	3-1/4	4-1/8	6-1/2	7-1/2
	200	31KR34						10					
	300	131KR54	14	4									
	500	E131KR64											
1-1/2	115	35KR46	45	1.0	3.8	23	18	11-3/8	9-1/2	4	4-7/8	6-1/2	7-1/2
	200	41KR36						11-5/8					
	300	141KR56	22	4									
	500	141KR66											
2	100	36KR47	45	1.0	4.2	23	27	12-3/8	10-1/8	5-3/8	6	8	9
	200	42KR37						12-5/8					
	300	42KR57	32	4									
	500	142KR67											
3	100	44KR49F1	60	1.7	8.8	35	69	14-3/8	11-1/8	6-5/8	N/A	9-1/2	N/A
	200	44KR39F1										N/A	N/A
	300	144KR59F3	85	3.5	13.0	45	82	N/A	12-1/2				

Shipping Weights above apply to Threaded Ends Only (except 3" which are Flanged Only)

For Flanged Ends contact factory for complete weight and dimensions

3" STAINLESS STEEL VALVES ARE SUPPLIED WITH FLANGED ENDS ONLY

MAGNATROL VALVE CORPORATION