

# BRONZE SOLENOID VALVES

Dependable • Packless



## TYPE "GR" FULL PORT - NORMALLY OPEN 1" TO 3" PIPE SIZE

*NO DIFFERENTIAL PRESSURE REQUIRED TO OPEN*

**OPERATION:**

Valve closes when energized and opens when de-energized. When the coil is energized the plunger presses the poppet, closing the pilot orifice, and opens a bleed passageway to permit pressure to build above the piston and seat it. Upon de-energizing the coil, the pilot orifice is opened, relieving the pressure above the piston allowing it to leave its seat. The bottom spring allows the valve to operate at zero pressure drop.

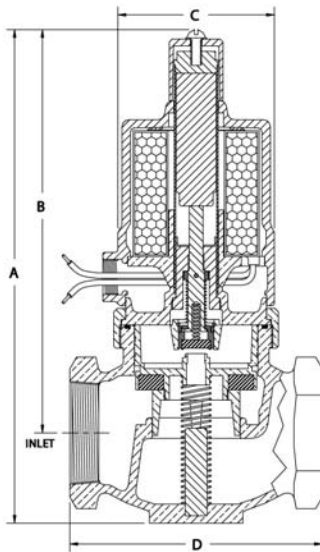

Strainers are recommended for use with solenoid valves  
(See page 19)

**CONSTRUCTION:** (\* Wetted parts)

- \*Valve Body - Cast Bronze, Globe Pattern - NPT ends
- \*Piston - Bronze  
Coil Enclosure - Malleable or Cast Iron, 1/2" NPS conduit conn.
- \*Plunger - 430 Stainless Steel
- \*Pilot Valve Stem - 303 Stainless Steel
- \*Pilot Valve Disc Holder - Brass
- \*Pilot Valve Seal - Buna N (Viton available)
- \*Bonnet Tube - 304 Stainless Steel
- \*Spring - 302 Stainless Steel
- \*Body Seal - Buna N or Non Asbestos Gasket
- \*Orifice Seal - Buna N (Viton or Glass Filled Teflon available)
- \*AC Shading Coil - Copper
- \*Stem Pin - Inconel  
Coil - Encapsulated Class B, 18" leads - (Class H available)



**FOR OPTIONS & ACCESSORIES  
SEE PAGES 24 & 25**

**APPLICATION:**

To control the flow of Water, Air, Gas, Solvents, Vacuum and any other fluids not reactive with construction materials and free of sediment. Buna N seating of the pilot and main orifices make the valves ideal for TIGHT SEATING, LOW PRESSURE and LOW FLOW conditions. Valve operates from zero to maximum differential pressure indicated in table. Valve must be mounted in horizontal pipe with solenoid enclosure vertical and on top.

**When you order please supply the following:**

- Pipe Size
- Valve Type
- Voltage (AC or DC)
- Hertz
- Fluid
- Fluid Temperature
- Max. Diff. Pressure
- Optional Features

(See pages 24 & 25)

Pipe Size Inches	Max. Diff. PSI	Type No.	Watts AC	Amps Hold 120-60	Amps Inrush 120-60	Watts DC	Ship Wt. Lbs.	Dimensions In Inches			
								A	B	C	D
1	20	† 18GR24	25	0.5	1.5	18	9	8-5/8	7-1/4	2-3/4	4-1/8
	35	33GR24	45	1.0	3.0	23	13	9-5/8	8-1/4	3-1/2	4-1/8
1-1/4	20	† 18GR25	25	0.5	1.9	18	10	9-3/8	7-3/4	2-7/8	4-3/8
	35	33GR25	45	1.0	3.2	23	14	10-1/4	8-3/4	3-1/2	4-3/8
1-1/2	15	† 18GR26	25	0.5	2.0	18	12	9-1/2	7-7/8	3-1/8	4-3/4
	25	33GR26	45	1.0	3.8	23	16	10-1/2	8-7/8	3-1/2	4-3/4
2	18	33GR27	45	1.0	4.2	23	21	11-1/4	9-1/4	3-3/4	5-3/4
	30	133GR27	65	1.5	4.5	33	21	11-1/4	9-1/4	3-3/4	5-3/4
2-1/2	13	37GR28	45	1.0	4.4	23	34	12-1/2	10	5-7/8	7-1/8
	25	43GR28	60	1.7	8.0	35	39	12-3/4	10-1/4	5-7/8	7-1/8
3	25	44GR29	60	1.7	8.8	35	47	13-5/8	10-5/8	6-5/8	8

† UL Listed Valves - Consult Factory

**MAGNATROL VALVE CORPORATION**